

A solo

CLASSIC STYLE

A01
FRASSINO SPAZZOLATO
LACCATO TERRA
BLUSHER LACQUERED
BRUSHED SOLID ASHWOOD
P. 6

A02
FRASSINO SPAZZOLATO LACCATO ROSSO
RED LACQUERED BRUSHED SOLID ASHWOOD
P. 12

COUNTRY STYLE

A03
FRASSINO SPAZZOLATO
LACCATO TORTORA
DOVE LACQUERED
BRUSHED SOLID ASHWOOD
P. 24

A04
FRASSINO NATURALE ANTICATO
NATURAL ASHWOOD ANTIQUE FINISH
P. 32

A05
FRASSINO SPAZZOLATO AVORIO DECAPÈ
NATURAL ASHWOOD IVORY PICKLED FINISH
P. 40

PROVENÇAL STYLE

A06
FRASSINO SPAZZOLATO
LACCATO TORTORA
DOVE LACQUERED BRUSHED
SOLID ASHWOOD
P. 48

A07
FRASSINO SPAZZOLATO AVORIO DECAPÈ
NATURAL ASHWOOD IVORY PICKLED FINISH
P. 58

A08
FRASSINO SPAZZOLATO
LACCATO LAVANDA
LAVENDER LACQUERED
BRUSHED SOLID ASHWOOD
P. 68

A09
FRASSINO SPAZZOLATO LACCATO BIANCO
WHITE LACQUERED BRUSHED SOLID ASHWOOD
P. 76

FIFTIES' AMERICAN STYLE

A10
FRASSINO NATURALE ANTICATO
NATURAL ASHWOOD ANTIQUE FINISH
P. 84

HAMPTONS STYLE

A11
FRASSINO SPAZZOLATO
LACCATO CARTA DA ZUCCHERO
SUGAR PAPER LACQUERED
BRUSHED SOLID ASHWOOD
P. 94

A12
FRASSINO SPAZZOLATO
LACCATO CARTA DA ZUCCHERO
SUGAR PAPER LACQUERED
BRUSHED SOLID ASHWOOD
P. 104

NORDIC STYLE

A13
FRASSINO SPAZZOLATO
LACCATO GRIGIO MEDIO
MEDIUM GREY LACQUERED
BRUSHED SOLID ASHWOOD
P. 112

A14
FRASSINO SPAZZOLATO
LACCATO CENERE
CINDER LACQUERED
BRUSHED SOLID ASHWOOD
P. 120

RAW STYLE

A15
FRASSINO SPAZZOLATO
LACCATO GRIGIO FUMO
SMOKE GREY LACQUERED
BRUSHED SOLID ASHWOOD
P. 130

A16
FRASSINO SPAZZOLATO
LACCATO BIANCO
WHITE LACQUERED
BRUSHED SOLID ASHWOOD
P. 138



CLASSIC

- STYLE -

PAESAGGI ROMANTICI, TIPICAMENTE TOSCANI,
DOVE FILARI DI CIPRESSI DEFINISCONO I PROFILI E MACCHIE DI VITIGNI
DISEGNANO FIGURE, INTRODUCENDO COLORI CALDI E MATERICI COME L'ORO,
LA RUGGINE E VARIE SFUMATURE DI VERDE E MARRONE CHE EVOCANO LE TONALITÀ
DELLA TERRA RICCA. UN GUSTO CLASSICO ITALIANO CHE SI RACCONTA IN UNA
CUCINA CARATTERIZZATA DA AMBIENTI IN PIETRA NATURALE E LEGNO, SUPERFICI
IN MARMO, TRAVERTINO E TERRACOTTA E MOBILI CHE PROFUMANO DI LEGNO,
ELEMENTI SOLIDI E DESTINATI A DURARE NEL TEMPO.

IN ROMANTIC TUSCAN LANDSCAPES, ROWS OF CYPRESS TREES
DEFINE CONTOURS AND PATCHES OF VINEYARDS CREATE PATTERNS,
INTRODUCING WARM, SUBSTANTIAL COLORS LIKE GOLD, RUST AND VARIOUS
SHADES OF GREEN AND BROWN THAT EVOKE THE SHADES OF THE RICH LAND.
CLASSIC ITALIAN TASTE IS EVIDENT IN A KITCHEN THAT FEATURES NATURAL
STONE AND WOOD, INCLUDING MARBLE, TRAVERTINE AND TERRACOTTA SURFACES
AND WOOD CABINETS - SOLID ELEMENTS THAT STAND THE TEST OF TIME.

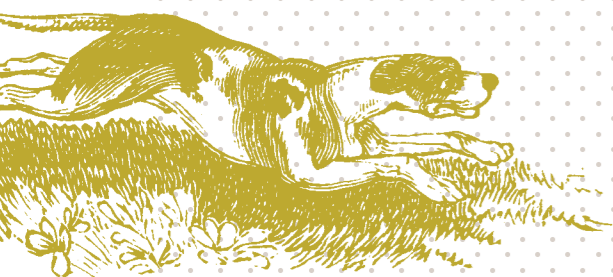

FRASSINO SPAZZOLATO LACCATO TERRA

Vetro gothic / Muratura finitura etruria tortora Dibiesse / Cappa in muratura in finitura etruria tortora Dibiesse con massello frassino spazzolato laccato terra / Top in travertino romano classico sp. 60 mm / Maniglia prestige laccata terra / Zoccolo in frassino spazzolato laccato terra.

BLUSHER LACQUERED BRUSHED SOLID ASHWOOD

Gothic glass / Dibiesse dove color etruria finish masonry / Masonry hood with blusher lacquered brushed solid ashwood profile / Roman travertine marble top, th. 60 mm / Handle prestige blusher lacquered finish / Blusher lacquered brushed solid ashwood plinth.



A





Colonne eleganti, basi attrezzate ed elementi ad elevata componibilità completano le funzioni della cucina creando un ritmo formale e cromatico vario e personalizzato.

Elegant tall units, equipped base units and modular elements lend the kitchen functionality while creating a customized, variable rhythm of shapes and colors.



FRASSINO SPAZZOLATO LACCATO ROSSO

Elementi a giorno frassino spazzolato laccato rosso con ripiani in acciaio /
Cappa in muratura finitura fondo bianco con massello frassino spazzolato laccato rosso /
Top marmo carrara sp. 40 mm / Schienali in acciaio / Bancone in rovere spazzolato anticato /
Maniglia art. 350 / Zoccolo in frassino spazzolato laccato rosso.

RED LACQUERED BRUSHED SOLID ASHWOOD

Red lacquered brushed solid ashwood doors and open elements with steel shelves / Masonry hood
fondo bianco finish with red lacquered brushed solid ashwood profile / Carrara marble top,
th. 40 mm / Steel back panel / Brushed oak antique finish worktop / Handle art. 350 /
Red lacquered brushed solid ashwood plinth.



A





Forme semplici e armoniose, materiali naturali e ambientazioni che rendono omaggio alla familiarità delle cucine di un tempo: la cucina Asolo, in frassino spazzolato laccato rosso con piani in marmo di Carrara, si propone ai nostalgici della tradizione attraverso il linguaggio del colore.

Simple, harmonious shapes, natural materials and settings that pay tribute to the hominess of kitchens of the past. The Asolo kitchen in red painted brushed ashwood with Carrara marble countertops uses a language of colors to express the nostalgia of tradition.





La cucina Asolo, dotata di tutti i comfort e soluzioni funzionali, permette di riassaporare situazioni e oggetti della memoria che sono parte vitale della quotidianità.

Offering exceptional convenience and functional solutions, the Asolo kitchen reinterprets settings and objects from the past that are a vital part of daily life.



La proposta è completata da una serie di elementi semicolonna, attrezzati o dedicati alla dispensa, con ante, zoccolo e piano in frassino spazzolato laccato rosso.

The layout features a series of medium-height units, either equipped with appliances or used for storage, with doors, kick boards and tops in red painted brushed ashwood.

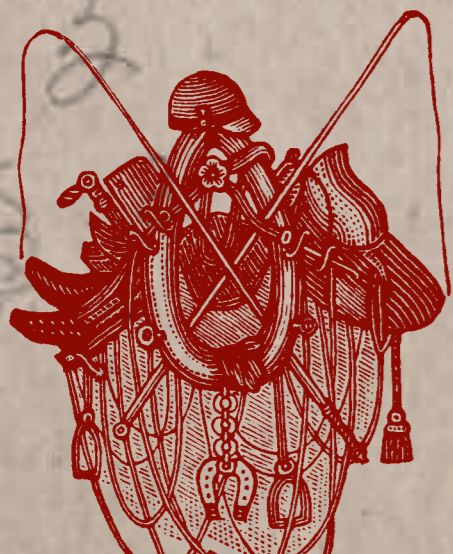

COUNTRY

- STYLE -

CASALI IMMERSI NELLA CAMPAGNA,
VIUZZE DI CIOTTOLI E PROFUMATI ORTI DI ERBE
AROMATICHE SCANDISCONO UN PAESAGGIO SUGGERITIVO
MA SEMPLICE, DOVE IL QUOTIDIANO È SCANDITO
DAI RITMI DELLA NATURA E DALLE SUE STAGIONALITÀ
ED IL TEMPO È VISSUTO COME UN VALORE. UN GUSTO ELEGANTE
E ALLO STESSO TEMPO RUSTICO, SI RACCONTA NEI TONI CALDI
DEL LEGNO MASSICCIO - SPESSO IN FINITURA DECAPÈ -
NELLE LINEE MORBIDE E SEMPLICI, NEGLI SPAZI INTIMI
E RILASSATI E NEGLI ELEMENTI DECORATIVI.

COUNTRY HOMES IMMERSED IN RURAL SETTINGS,
WHERE PEBBLED LANES AND AROMATIC HERB GARDENS
ARE SCATTERED ACROSS THE SIMPLE YET APPEALING LANDSCAPE,
WHERE DAILY LIFE IS IN TOUCH WITH THE RHYTHM OF NATURE
AND ITS SEASONS AND WHERE THE VALUE OF TIME IS UNDERSTOOD.
THE WARM TONES OF SOLID WOOD, PICKLED FINISHES, DECORATIVE
ELEMENTS, SOFT SIMPLE LINES AND COMFORTABLE, INTIMATE
SPACES CREATE A STYLE THAT IS BOTH RUSTIC AND ELEGANT.

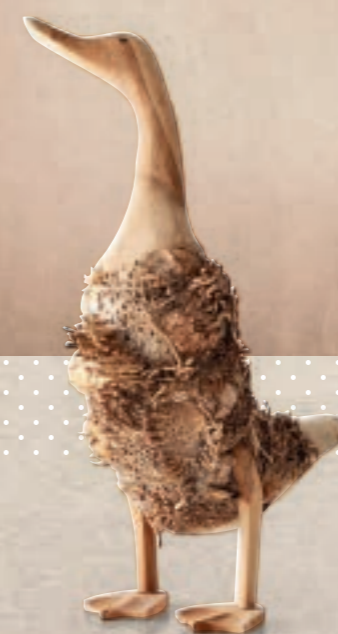
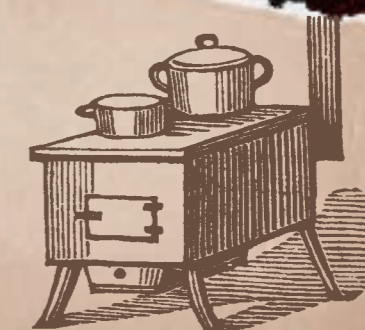

FRASSINO SPAZZOLATO LACCATO TORTORA

Muratura finitura etrusca carso e fondo bianco / Top piastrellato i Sassi Biancone sp. 38 mm / Maniglie art. 351 / Zoccolo in frassino spazzolato laccato tortora.

DOVE GREY LACQUERED BRUSHED SOLID ASHWOOD

Masonry etrusca karst and fondo bianco finish / I Sassi tiled top, Biancone color, th. 38 mm / Handle art 351 / Dove lacquered brushed solid ashwood plinth.





Eleganza e praticità contraddistinguono il blocco autonomo isola/lavoro con piano piastrellato in finitura I Sassi Biancone e struttura in muratura etrusca carso dove è inserito un pratico tagliere estraibile in Teflon. Al soffitto è appesa la cornice in muratura per isola completa di sostegni rigidi e ripiani in tubi finitura brunita che si abbina alla cornice in muratura della cappa.

Elegance and practicality are the distinguishing characteristics of the island/work area. It features a tiled countertop in I Sassi Biancone finish and a masonry structure in etrusca carso that holds a practical removable Teflon cutting board. The masonry ceiling-hung rack for island unit is supplied with burnished finish shelves and matches the masonry frame of the hood.



La proposta è completata da una serie di elementi dispensa semicolonna con ante in finitura frassino spazzolato laccato tortora, e boiserie con mensole in legno di frassino: Asolo racchiude l'esperienza e le virtù di una cucina tradizionale attraverso stili attuali come la funzionalità e l'uso di attrezzature e tecnologie avanzate.

The layout features a series of storage units with dove grey brushed painted ashwood finish and panelling with ashwood shelves. Asolo provides the appearance and benefits of a traditional kitchen while incorporating contemporary characteristics like functionality and cutting-edge features and technology.

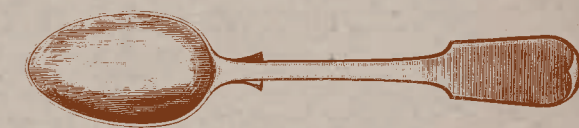

FRASSINO NATURALE ANTICATO

Top marmo nero assoluto Zimbabwe levigato opaco sp. 30 e 80 mm /
Maniglia art. 351 / Zoccolo in frassino naturale.

NATURAL ASHWOOD ANTIQUE FINISH

Matt polished Zimbabwe absolute black tp, th. 30 e 80 mm /
Handle art. 351 / Natural ashwood antique finish plinth.





Una composizione dai toni caldi per la presenza del frassino naturale finitura anticato, arricchita dalle note contemporanee del marmo nero assoluto Zimbabwe di piani e schienali. La cappa Asolo prevede il cono in acciaio inox, massello perimetrale e barbacani in legno di frassino.

A kitchen featuring the warm colors of antiqued natural ashwood finish is enhanced by the contemporary look of the Zimbabwe absolute black marble countertops and splashback panels. The Asolo hood combines a stainless steel cone with solid wood trim and brackets made of ashwood.



Accessori arredativi di completamento, ormai divenuti un'esigenza estetico-funzionale, arricchiscono cassetti, cesti e colonne. Dal porta-posate in legno ai cestelli estraibili; mensole portaoggetti e spazi contenitivi; decorativi e comodi optional.

Accessories have now become an aesthetic and functional necessity, enhancing drawers, baskets and tall units. Special features include wood cutlery trays, removable baskets, storage shelves, storage areas, and convenient and decorative options.



Accessories

FRASSINO SPAZZOLATO AVORIO DECAPÈ

Top in laminato magnolia con massello legno frassino naturale anticato /
Maniglia art. 350 / Zoccolo in frassino avorio decapè.

NATURAL ASHWOOD IVORY PICKLED FINISH

Magnolia laminate top with natural ashwood antique finish wood profile /
Handle art. 350 / Natural ashwood ivory pickled finish plinth.





La luminosità della finitura avorio decapè e l'armonia compositiva dettano i ritmi di questa proposta lineare impreziosita da interessanti temi strutturali come l'elemento base a giorno con decoro o la libreria che arreda la zona living.

A bright pickled ivory finish and a harmonious layout set the rhythm for a linear design that is enhanced by unique structural elements like the decorated open base unit and the bookcase in the living area.



PROVENÇAL

- STYLE -

UN PORTONCINO COLOR LAVANDA AFFACCIATO SULLA VIA, UN VILLAGGIO ARROCCATO SULLA ROCCIA, PROFUMI FRESCHI E SAPORI INTENSI, PASSEGGIATE IMMERSE IN SUGGERITIVE DISTESE DI LAVANDA: LA PROVENZA, UNA TERRA RICCA DI STORIA ED EMOZIONI, DOVE NON È RARO IMBATTERSI IN QUALCHE ANTICA SORPRESA. DALLA FRANCIA DEL SUD LO STILE PROVENZALE PORTA NELLE CASE UNA DOLCEZZA ROMANTICA E IL SAPORE DI ALTRI TEMPI CHE SI SPOSA CON UN GUSTO RUSTICO MA ELEGANTE E SI DECLINA IN NUANCE PASTELLO, COLORI ARMONIOSI E FRESCHI, SOPRATTUTTO DELLE TONALITÀ TENDENTI AL BIANCO ED ÉCRU, MA ANCHE AZZURRO, LAVANDA, VERDE PALLIDO, OVVERO I COLORI DELLA TERRA DI PROVENZA.

A PASTEL COLORED DOOR FACING THE STREET, A VILLAGE PERCHED ON THE ROCKS, FRESH FRAGRANCES AND INTENSE FLAVOURS, LANDSCAPES IMMERSED IN EXPANSES OF LAVENDER - PROVENCE, AN ENTHRALLING LAND WITH A RICH HISTORY, WHERE IT IS NOT UNUSUAL TO STUMBLE ACROSS ANCIENT WONDERS. SOUTHERN FRANCE'S PROVENÇAL STYLE BRINGS TO YOUR HOME A RUSTIC YET ELEGANT LOOK THAT COMBINES THE FLAVOUR OF THE PAST WITH ROMANTIC WARMTH. THE LOOK IS CREATED WITH HARMONIOUS, FRESH PASTEL COLORS LIKE SHADES OF WHITE AND ÉCRU, AS WELL AS BLUE, LAVENDER, PALE GREEN AND PROVENÇAL EARTH TONES.

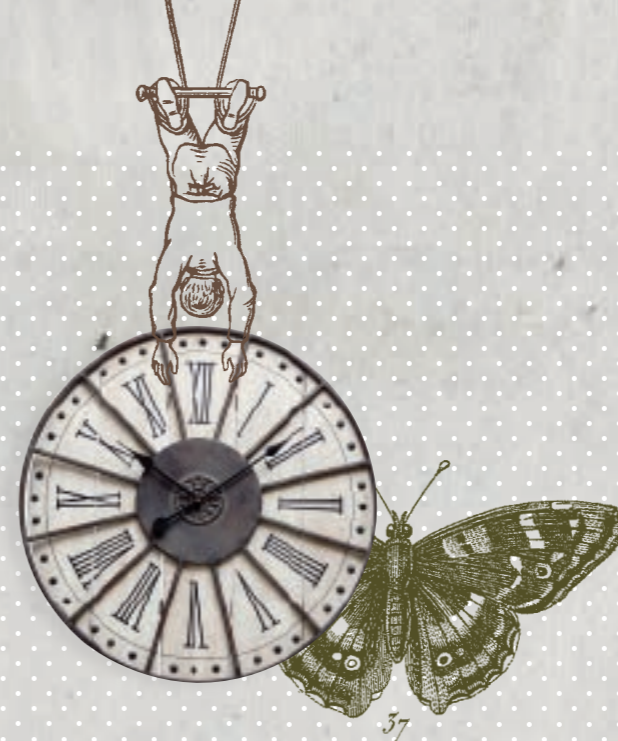

FRASSINO SPAZZOLATO LACCATO TORTORA

Elementi a giorno frassino spazzolato laccato tortora con ripiani in acciaio /
Top in laminato con bordo unicolor gres sp. 60 mm / Bancone in frassino spazzolato laccato
tortora sp. 60 mm e vetro temperato laccato marmotta con profilo acciaio sp. 30 mm /
Seconda versione con bancone in rovere termocotto sp. 60 mm /
Maniglia prestige laccato tortora / Zoccolo in frassino spazzolato laccato tortora.

DOVE LACQUERED BRUSHED SOLID ASHWOOD

Dove lacquered brushed solid ashwood doors and open elements with steel shelves / Gres laminate top
with unicolor edge, th. 60 mm / Worktop with brushed dove grey lacquered oak, th. 60 mm and marmot
brown glass top with steel profile, th. 30 mm / Second version with Termocotto oak worktop th. 60 mm /
Handle Prestige dove lacquered finish / Dove lacquered brushed solid ashwood plinth.



06







Un elemento a mensole completa la composizione sostituendo il fianco di finitura: un pannello laccato opaco dello stesso colore delle ante è arricchito da mensole in acciaio per tutta l'altezza donando un pizzico di contemporaneità a un design romantico e accogliente.

A shelves unit terminates the composition replacing the end side panel: a matt lacquered panel in the same color of the doors is enriched by steel shelves for the full height. It adds a touch of contemporary design to a cozy and romantic layout.



La scelta raffinata della finitura in frassino spazzolato laccato interpreta l'essenza con una piacevole sensazione tattile. Alle tonalità neutre di piani ed elementi compositivi si alternano inoltre **dettagli in acciaio, come i ripiani degli elementi a giorno**, che introducono note dal gusto contemporaneo.

*The sophisticated dove grey painted brushed ashwood finish makes the wood pleasing to the touch. The neutral colors used for the countertops and cabinets alternate with **stainless steel details like open elements shelves**, adding a touch of contemporary taste.*



Il bancone in rovere termocotto si sovrappone al piano di lavoro creando un gioco di livelli interessante che esprime differenti funzionalità. L'elemento a giorno a uso gambone oltre ad essere elemento di supporto è interpretato come spazio contenitivo.

The termocotto oak counter overlaps the worktop, creating an intriguing play of heights that suggests different functions. The open element acts as a support and also provides additional storage space.



FRASSINO SPAZZOLATO AVORIO DECAPÈ

Vetro stop sol / Elementi a giorno laccato opaco cammeo / Top in marmo porfido marrone
sp. 30 e 80 mm / Maniglia art. 351 / Zoccolo in frassino finitura decapè avorio.

NATURAL ASHWOOD IVORY PICKLED

Natural ashwood ivory pickled finish and stop sol glass doors / Cameo lacquered brushed
solid ashwood open elements / Brown porphyry top, th. 30 and 80 mm / Handle art. 351 /
Natural ashwood ivory pickled finish plinth.



Lo spazio angolare può essere sfruttato con l'impiego di una cabina armadio dispensa o portautensili con ante personalizzate, attrezzata con ripiani a misura ed elementi contenitivi. La personalizzazione di Asolo si esplicita anche nell'elegante elemento cappa in muratura.

The corner space can be used for a larder unit or a utensils-storage unit that features customized doors and is equipped with made-to-measure shelves and storage elements. The elegant masonry hood is also a custom Asolo feature.





L'eleganza del design si esplicita nelle differenti lavorazioni delle ante e nelle soluzioni a giorno arricchite da lavorazioni intagliate e decori.

The elegance of the design is apparent in the different finishes of the doors, as well as the carvings and decorations that embellish the open cabinets.





La cucina Asolo si coordina di molteplici elementi accessori come l'elegante tavolo in frassino finitura decapè avorio con piano impiallacciato, giropanca contenitivo e raffinate sedie in legno con comodo sedile in paglia o legno.

Asolo kitchens can be coordinated with numerous accessories, like the elegant pickled ivory ashwood table with veneer top, the corner storage bench and the sophisticated wood chairs with comfortable rush or wooden seats.

FRASSINO SPAZZOLATO LACCATO LAVANDA

Boiserie laccato opaco visone con mensole in acciaio / Cappa in muratura finitura visone con massello frassino spazzolato laccato lavanda / Top in acciaio sp. 80 mm / Zoccolo in frassino spazzolato laccato lavanda.

LAVENDER LACQUERED BRUSHED SOLID ASHWOOD

Lavender lacquered brushed solid ashwood doors / Mink matt lacquered boiserie with steel shelves / Masonry hood mink lacquered finish with lavender lacquered brushed solid ashwood profile / Steel top, th. 80 mm / Lavender lacquered brushed solid ashwood plinth.



08

A







Una soluzione interpretata con personalità attraverso un gioco di contrasti tra i colori pastello e gli elementi in acciaio, tra il segno decorativo dell'anta telaio e la forma monolitica della cappa, differenti sistemi di apertura funzionali e soluzioni a giorno.

A design with personality, it creates a play of contrasts between pastel colors and steel elements, between the decorative look of the framed doors and the monolithic shape of the hood, and between different opening systems and open cabinets.



Nota caratteristica un'ampia **boiserie attrezzata con mensole in acciaio**, strumenti funzionali nell'organizzazione degli oggetti ed allo stesso tempo elementi decorativi nel creare un ritmo formale regolare tra pieni e vuoti.

*A characteristic feature of the design is the wide **panelling fitted with steel shelves**. In addition to being useful for organizing objects, the shelves are decorative elements that create a rhythmic alternation of solids and voids.*



FRASSINO SPAZZOLATO LACCATO BIANCO

Vetro texture colore corda / Top in marmo di Carrara sp. 30 mm /
Bancone in rovere spazzolato anticato sp. 60 mm / Maniglia prestige
cromata / Zoccolo in frassino spazzolato laccato bianco.

WHITE LACQUERED BRUSHED SOLID ASHWOOD

White lacquered brushed solid ashwood and rope textured glass doors / Carrara marble
top, th. 30 mm / Brushed oak antique finish worktop th. 60 / Handle Prestige chrome finish /
White lacquered brushed solid ashwood plinth.







Le forme della tradizione, il profumo del legno massiccio inserito nella cucina per esaltare la venatura del frassino e la luminosità del bianco si fondono nella stanza per creare un ambiente di grande personalità: ogni elemento è in finitura laccato spazzolato poro aperto, soluzione che permette di amplificare la dimensione materica delle ante.

The combination of traditional shapes, solid wood that highlights the grain of the ashwood, and the radiant white finish create a setting with great character. Each furniture element features an open-grain brushed and painted finish that accentuates the material dimension of the doors.



FIFTIES' AMERICAN

- STYLE -

UN QUARTIERE DI CHICAGO DINAMICO E FRIZZANTE, DOVE LA VOGLIA DI INNOVAZIONE SI MESCOLA AD UNA NUOVA CREATIVITÀ: LA CASA DIVENTA IL RIFLESSO DI QUELLO CHE TELEVISIONE E CINEMA AMERICANO SUGGERISCONO, DALLO STILE, ALLA MODA, FINO AGLI USI E COSTUMI. UN'ATMOSFERA CHE SI ISPIRA AGLI ANNI '50, DOVE IL COLORE PONE L'ACCENTO SUI DETTAGLI E SULLA NUOVA INTERPRETAZIONE DI PATTERN E GRAFICHE, LE FORME ALTERNANO LINEE GEOMETRICHE A PROFILI ARROTONDATI, MATERIALI DIFFERENTI DIALOGANO CON CARATTERE CREANDO ORIGINALI SOLUZIONI DAL GUSTO VINTAGE.

A LIVELY, DYNAMIC DISTRICT OF CHICAGO, WHERE A DESIRE FOR INNOVATION BLENDS WITH A NEW CREATIVITY. THE HOME REFLECTS THE STYLES AND FASHIONS, AND EVEN THE HABITS AND CUSTOMS, DEPICTED IN AMERICAN TELEVISION AND FILMS. AN ATMOSPHERE INSPIRED BY THE 1950S, WHERE COLOR HIGHLIGHTS THE DETAILS AND ACCENTUATES THE NEW INTERPRETATION OF PATTERNS AND DESIGNS. SHAPES ALTERNATE BETWEEN GEOMETRIC LINES AND ROUNDED CONTOURS, WHILE A STRIKING COMBINATION OF DIFFERENT MATERIALS CREATES ORIGINAL SOLUTIONS HAVING A VINTAGE FLAVOUR.



FRASSINO NATURALE ANTICATO

Frontali in frassino naturale anticato / Muretti in laminato con bordo in unicolor bianco dax stone, sp. 100 mm / Elementi a giorno frassino spazzolato laccato rosso / Cappa Asolo con massello frassino naturale anticato / Top in laminato con bordo unicolor bianco dax stone, sp. 100 mm / Maniglia art. 355 / Zoccolo in frassino naturale.

NATURAL ASHWOOD ANTIQUE FINISH

Natural ashwood antique finish doors / Laminate dax stone masonry style panels with unicolor edge th. 100 mm / Red lacquered brushed solid ashwood open elements / Masonry hood with natural ashwood antique finish profile / White dax stone laminate top with unicolor edge, th. 100 mm / Handle art. 355 / Natural ashwood antique finish plinth.





La soluzione originale di incassare gli elementi compositivi in **cornici strutturali in laminato unicolor bianco Dax Stone** e di utilizzare la stessa finitura per alcune ante, permette di creare un ritmo cromatico che racconta le forme e i volumi della cucina e ne enfatizza il design pulito e lineare.

*This original layout sets the furniture elements within **structural frames that have a Dax Stone white finish** and then uses this same finish for several of the cabinet doors. The unique arrangement lends a chromatic rhythm to the shapes and volumes of the kitchen and emphasizes the clean, linear design.*



Un design che interpreta in modo consapevole e originale i canoni della tradizione proponendo profili geometrici in frassino naturale anticato per la cappa Asolo, realizzando una piacevole sintesi tra contemporaneo e classico.

The tenets of tradition are deliberately reinterpreted in a novel way. The design features the Asolo hood with geometric trim in antiqued natural ashwood, creating an appealing blend of contemporary and classic styles.



HAMPTONS

- STYLE -

DAL LUSO, DALLA FRENESIA E DALLE LUCI DELLA GRANDE MELA, AL RELAX E ALLA QUIETE DI UN'OASI DI PACE CIRCONDATA DA RIGOGLIOSI PAESAGGI VERDI E LUNGHE SPIAGGE BIANCHE. GLI HAMPTONS, LONTANI DALLE LUCI DI NEW YORK, RAPPRESENTANO IL RIFUGIO IDEALE DI LONG ISLAND, CARATTERIZZATO DALLE ATMOSFERE RAFFINATE E ALLO STESSO TEMPO INFORMALI E CASUAL. AMBIENTI LUMINOSI, TONALITÀ NEUTRE ED OGGETTI NATURALI EVOCANO IL TEMA DEL MARE E DELLE VACANZE, UNA SCENOGRAFIA IDEALE PER UNA CUCINA ISPIRATA AD UNO STILE COLONIALE REINTERPRETATO, DOVE ELEMENTI RUSTICI INCONTRANO CITAZIONI CONTEMPORANEE, DALLE LINEE PULITE E LINEARI.

FROM THE LUXURY, BUSTLE AND BRIGHT LIGHTS OF THE BIG APPLE TO THE QUIET TRANQUILLITY OF A PEACEFUL OASIS SURROUNDED BY LUSH GREEN LANDSCAPES AND LONG WHITE BEACHES. LOCATED FAR FROM THE LIGHTS OF NEW YORK, THE HAMPTONS ARE THE PERFECT LONG ISLAND GETAWAY, CHARACTERIZED BY REFINED, YET CASUAL SETTINGS. BRIGHT ROOMS, NEUTRAL COLORS AND NATURAL OBJECTS EVOKE THE IDEA OF VACATIONS BY THE SEA AND CREATE THE PERFECT BACKDROP FOR KITCHENS HAVING AN UPDATED COLONIAL STYLE WITH CLEAN, CRISP LINES THAT BLENDS RUSTIC AND CONTEMPORARY ELEMENTS.

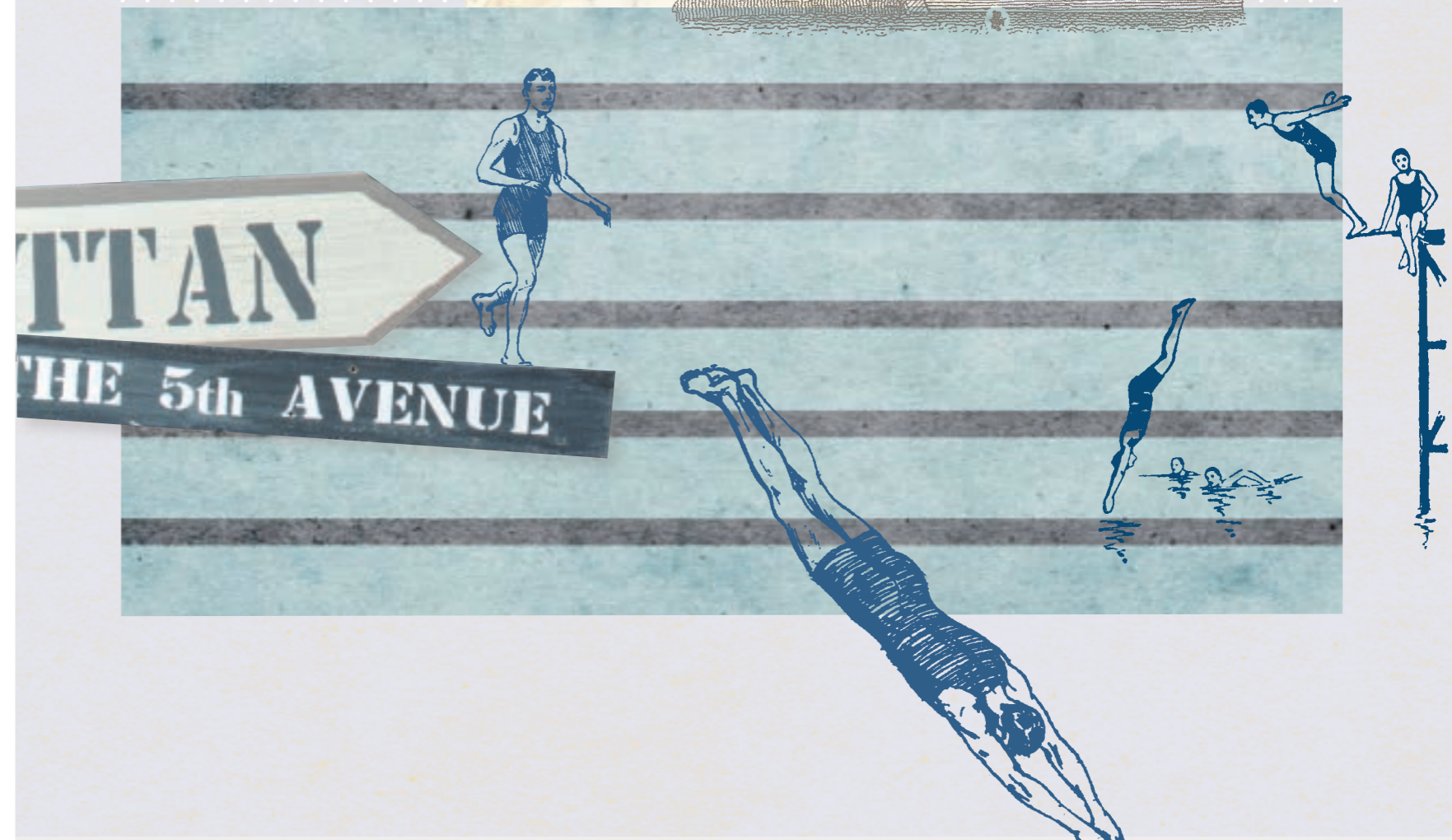
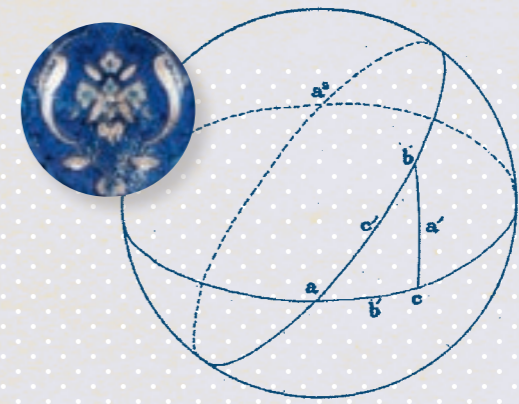

FRASSINO SPAZZOLATO LACCATO CARTA DA ZUCCHERO

Frontali in frassino spazzolato laccato carta da zucchero e vetro stop sol / Muratura finitura provenza bianco / Cappa muratura finitura provenza bianco con massello frassino spazzolato laccato carta da zucchero / Top in laminato con bordo unicolor pietra piacentina sp. 60 mm / Bancone in rovere spazzolato anticato sp. 60 mm / Maniglia art. 355.

SUGAR PAPER LACQUERED BRUSHED SOLID ASHWOOD

Sugar paper lacquered brushed solid ashwood and stop sol glass doors / White provenza masonry / Masonry hood white provenza finish with sugar paper lacquered brushed solid ashwood profile / Piasentine stone laminate top with unicolor edge, th. 60 mm / Brushed oak antique finish worktop th. 60 mm / Handle art. 355.



11

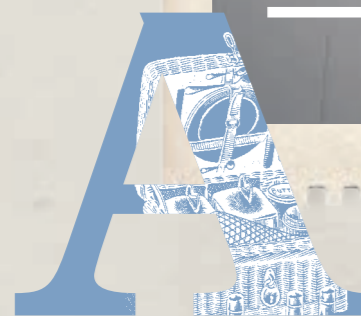





Un ambiente saturo di luminosità, in cui la luce mette in primo piano il design dinamico amplificandone l'eleganza. Asolo gioca sulle tonalità del carta da zucchero, del bianco e del legno finitura anticato, permettendo di assaporare un'atmosfera quotidiana raffinata.

A radiant setting in which light highlights the dynamic design and accentuates its elegance. The white, sugar paper and antiqued wood finishes create a play of colors that lends the home a sophisticated atmosphere.



Una composizione semplice e lineare che evidenzia il gusto per un'estetica fresca e originale, dove il frassino spazzolato laccato carta da zucchero esalta la geometria dei volumi e la matericità del piano lavoro in finitura rovere spazzolato anticato sp. 60 mm.

A simple, linear arrangement highlights the fresh, original look. The sugar paper painted brushed ashwood finish accentuates the shapes of the volumes and emphasizes the solidity of the 60 mm thick antiqued brushed oak finish worktop.



Il gusto squisito delle vetrine con inglesina coinvolge, oltre ai pensili, anche le colonne, attrezzate con cestelli contenitivi e ripiani scorrevoli.

The exquisite appeal of glass doors with glazing bars is a feature of the wall units, as well as the tall units, which are equipped with storage baskets and sliding shelves.



FRASSINO SPAZZOLATO LACCATO CARTA DA ZUCCHERO

Frontali in frassino spazzolato laccato carta da zucchero / Muratura finitura acquerello bianco / Elementi laterali a giorno in frassino naturale anticato / Top piastrellato i sassi botticino sp. 38 mm / Maniglia art. 350.

SUGAR PAPER LACQUERED BRUSHED SOLID ASHWOOD

Sugar paper lacquered brushed solid ashwood and gothic glass doors / White Acquerello finish masonry / Natural ashwood antique finish open elements / I sassi tiled top, botticino color, th. 38 mm / Handle art. 350.



12

A







L'isola di lavoro centralizzata si caratterizza per il piano piastrellato e per il porta mestoli in tinta con le ante. Le pareti sono rivestite in frassino naturale anticato arricchite da mensolature.

The central work island features a tile top and a cooking utensil holder that matches the cabinet doors. The walls are panelled in antiqued natural ashwood and decorated with shelving.



NORDIC

- STYLE -

FIORDI INCUNEATI, VERDI INSENATURE E TORTUOSI CANALETTI INTRODUCONO AD UNA CITTÀ DALLE ATMOSFERE CONTEMPORANEE: STOCCOLMA, FAMOSA PER IL SUO STRAORDINARIO LIVELLO DI PROGRESSO E PER UNA PECULIARE ATTENZIONE VERSO TUTTO CIÒ CHE È TENDENZA, INTERPRETA UNA PERFETTA COMBINAZIONE TRA AMBIENTE NATURALE E STILE DIVITA COSMOPOLITA. IL LEGAME TRA LE ARCHITETTURE CONTEMPORANEE E IL PAESAGGIO È VERAMENTE ESSENZIALE, ANCHE NELLA SCELTA DEL LEGNO COME MATERIALE PRIVILEGIATO, DA PREFERIRSI NELLE VERSIONI E NEI COLORI NATURALI. UN'ESTREMA FUNZIONALITÀ E VIVIBILITÀ ISPIRA LO SPAZIO CUCINA DOVE LA PULIZIA E LA LUMINOSITÀ DEL BIANCO SI FONDONO AD ATMOSFERE ACCOGLIENTI.

TAPERING FJORDS, GREEN INLETS AND WINDING CHANNELS FORM THE GATEWAY TO STOCKHOLM, A CITY KNOWN FOR ITS CONTEMPORARY ATMOSPHERE. FAMOUS FOR ITS EXTRAORDINARY LEVEL OF DEVELOPMENT AND A UNIQUE INTEREST IN ALL THINGS TRENDY, IT IS THE PERFECT BLEND OF NATURAL SETTINGS AND A COSMOPOLITAN LIFESTYLE: THE FUNDAMENTAL CONNECTION BETWEEN THE LANDSCAPE AND STOCKHOLM'S CONTEMPORARY ARCHITECTURE IS EVIDENT IN THE USE OF WOOD AS THE PRIMARY MATERIAL, WITH A PREFERENCE FOR NATURAL LOOKS AND COLORS. KITCHENS PLACE AN EMPHASIS ON FUNCTIONALITY AND COMFORT, WITH CLEAN, BRIGHT WHITE BLENDING INTO WELCOMING SURROUNDINGS.

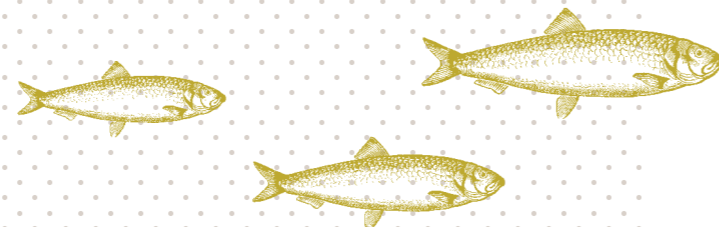

FRASSINO SPAZZOLATO LACCATO GRIGIO MEDIO

Frontali in frassino spazzolato laccato grigio medio / Elementi a giorno frassino spazzolato laccato grigio fumo con ripiani in acciaio / Top laminato con bordo unicolor ardesia sp. 40 mm e acciaio sp. 80 mm / Maniglia prestige cromata / Zoccolo in frassino spazzolato laccato grigio medio.

MEDIUM GREY LACQUERED BRUSHED SOLID ASHWOOD

Medium grey lacquered brushed solid ashwood doors / Smoke grey open elements with steel shelves / Ardesia laminate top with unicolor edge, th. 40 mm, and steel top, th. 80 mm / Handle Prestige chrome finish / Medium grey lacquered brushed solid ashwood plinth.



13

A





Il forte abbinamento delle essenze lignee all'acciaio della cappa Collier a parete e dei ripiani degli elementi a giorno dà risultati affascinanti e produce la piacevole sensazione di abitare una cucina contemporanea e familiare allo stesso tempo.

A bold combination of wood and steel (used for the Collier wall hood and the shelves of the open cabinets) creates an appealing look that lends the kitchen a pleasant feeling of being both contemporary and homey.



Cassettoni e cestelli estraibili, organizzati per contenere oggetti d'uso, stoviglie ed alimenti, garantiscono efficienza e scorrevolezza assolutamente unici. Una funzionalità giocosa ed originale è introdotta dalle **mensole Tetris**, che oltre a contenere si declinano come elementi decorativi di forte caratterizzazione.

*Removable baskets and drawers, arranged to hold cookware, dishes and food, ensure exceptional efficiency and fluid sliding. The **Tetris shelves** introduce a playful and original element of functionality, providing storage space while also acting as bold decorative elements.*



Norway
Sweden
Denmark

FRASSINO SPAZZOLATO LACCATO CENERE

Frontali in frassino spazzolato laccato cenere e acciaio satinato / Vetro stop sol / Muretti in laminato muro 123 con bordo in unicolor, sp. 100 mm / Elementi a giorno laccato opaco cenere / Top in laminato con bordo unicolor muro sp. 40 mm e acciaio satinato sp. 12 mm / Bancone in frassino spazzolato laccato cenere sp. 60 mm / Maniglia art. 355 / Zoccolo frassino spazzolato laccato cenere e alluminio brillante.

CINDER LACQUERED BRUSHED SOLID ASHWOOD

Cinder lacquered brushed solid ashwood, steel and stop sol glass doors / Muro 123 laminate with unicolor edge masonry style panels, th.100 mm / Cinder lacquered brushed solid ashwood open elements / Muro laminate top with unicolor edge, th. 40 mm, and stainless steel top th. 12 mm / Cinder lacquered brushed solid ashwood worktop th. 60 mm / Handle art. 355 / Cinder lacquered brushed solid ashwood and aluminium plinths.



14





Una composizione giovane e conviviale, pensata per ambienti aperti dove cucina e zona living sono completamente integrati. Una nuova spontaneità caratterizzata dall'abbinamento del frassino spazzolato laccato cenere all'acciaio, in un'originale dimensione contemporanea dal gusto nordico.

A fresh, appealing layout designed for open settings that feature kitchens as an integral part of the living area. A new spontaneity is apparent in the pairing of ashwood-grey painted brushed ashwood with steel, creating a unique contemporary look inspired by Nordic design.





Uso e vivibilità si manifestano negli elementi complementari alla cucina, come il tavolo multifunzione dotato di gamba-contenitore o le **mensole in laminato** caratterizzate da un design lineare che permette di organizzare gli oggetti del quotidiano in linee essenziali e rigorose.

*Functionality and convenience are evident in the furniture elements that complement the kitchen, such as the multi-functional table with a base that doubles as a storage unit and the linear **laminated shelves** that allow everyday objects to be organized neatly and precisely.*



RAW

- STYLE -

OLTRE IL PONTE DI BROOKLYN, NEL QUARTIERE DI WILLIAMSBURG, SI RACCONTA UN'ATMOSFERA UN PO' FUORI DAGLI SCHEMI, DOVE CONCEPT STORE E SHOWROOM SI ALTERNANO A GALLERIE D'ARTE E GARAGE SALE; UN VISSUTO UNDERGROUND CHE VALORIZZA GLI SPAZI INDUSTRIALI PER TRASFORMARLI IN LOFT DI DESIGN CHE SONO AL TEMPO STESSO OGGETTO E CONTENITORE DEGLI INTERESSI DI CHI CI ABITA. LO STILE È VIBRANTE E MOLTO PERSONALE, LA CUCINA UN AMBIENTE IMPORTANTE, CARATTERIZZATO DA COLORI OPACHI, SUPERFICI RUVIDE E GREZZE, DALL'ASPETTO INCOMPIUTO: ATTREZZATA CON ELEMENTI PROFESSIONALI IN ACCIAIO SI ARRICCHISCE DI UNA DIMENSIONE ACCOGLIENTE GRAZIE AL LINGUAGGIO MATERICO DEL LEGNO E DEL TESSUTO.

WILLIAMSBURG, WHICH LIES ACROSS THE BROOKLYN BRIDGE, HAS A BOHEMIAN ATMOSPHERE WHERE SHOWROOMS AND CONCEPT STORES INTERMINGLE WITH ART GALLERIES AND SHOPS SELLING VINTAGE GOODS. IN THIS 'UNDERGROUND' DISTRICT, INDUSTRIAL SPACES HAVE BEEN CONVERTED INTO DESIGNER LOFTS THAT REFLECT THE PERSONALITIES AND INTERESTS OF THEIR INHABITANTS. THE STYLE IS VIBRANT AND PERSONAL, WITH THE KITCHEN PLAYING A LEADING ROLE. FEATURING OPAQUE COLORS AND ROUGH, RAW SURFACES WITH AN UNFINISHED LOOK, IT HAS PROFESSIONAL STEEL EQUIPMENT AND IS ENHANCED BY THE WARMTH CREATED THROUGH THE USE OF WOOD AND FABRIC.

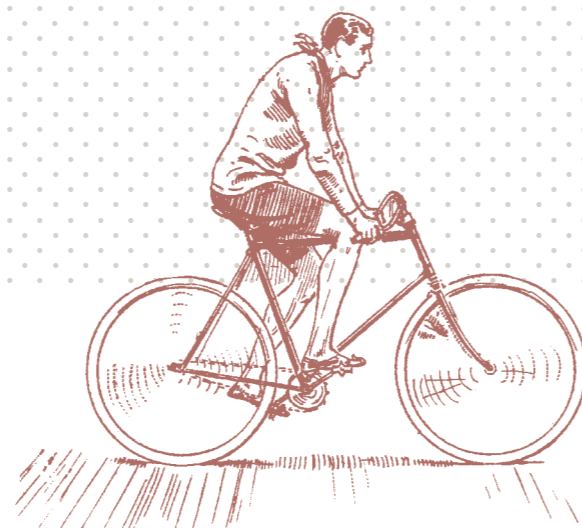

FRASSINO SPAZZOLATO LACCATO GRIGIO FUMO

Frontali in frassino spazzolato laccato grigio fumo e acciaio satinato / Elementi a giorno frassino spazzolato laccato grigio fumo / Top e fianconi in acciaio satinato sp. 80 e 12 mm / Bancone in rovere spazzolato anticato sp. 60 mm / Maniglia art. 234 / Zoccolo in frassino spazzolato laccato grigio fumo e alluminio brillante.

SMOKE GREY LACQUERED BRUSHED SOLID ASHWOOD

Smoke grey lacquered brushed solid ashwood and steel doors and open elements / Stainless steel top, th. 80 and 12 mm / Brushed oak antique finish worktop, th. 60 mm / Handle art. 234 / Smoke grey lacquered brushed solid ashwood and aluminium plinths.

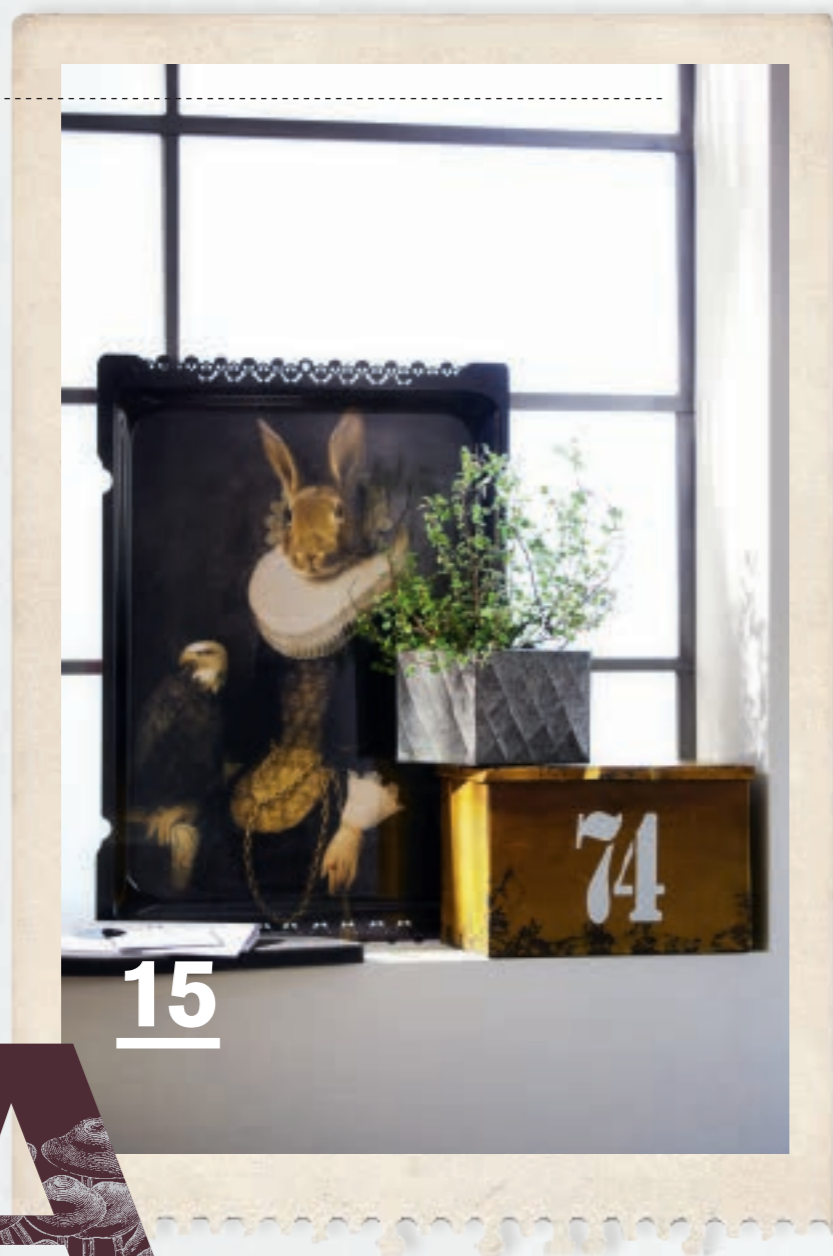

A







L'area lavoro centralizzata trova il proprio naturale prolungamento nella boiserie, in finitura rovere spazzolato anticato, attrezzata con mensole coordinate, creando un gioco tra pieni e vuoti, volumi e linee. La dimensione funzionale si esplicita inoltre nelle cabine armadio contestualizzate in cucina: vere e proprie soluzioni di massima efficienza e pulizia estetica.

The panelling in antiqued brushed oak finish fitted with matching shelves is a logical extension of the central work area, creating a play of solids and voids, of shapes and lines. The functional nature of the kitchen is also apparent in the larder units, which provide highly efficient storage solutions and feature clean lines.



Il calore della materia e la fusione di un colore dal gusto contemporaneo sono le peculiarità di una cucina che comunica un'estetica ricercata e allo stesso tempo razionale, capace di organizzare lo spazio con contenitori di diversa dimensione per contenere i molteplici oggetti d'uso quotidiano.

Warm materials and contemporary colors are unique aspects of a kitchen that is both sophisticated and practical. The space is arranged with containers of different sizes that store a variety of everyday objects.

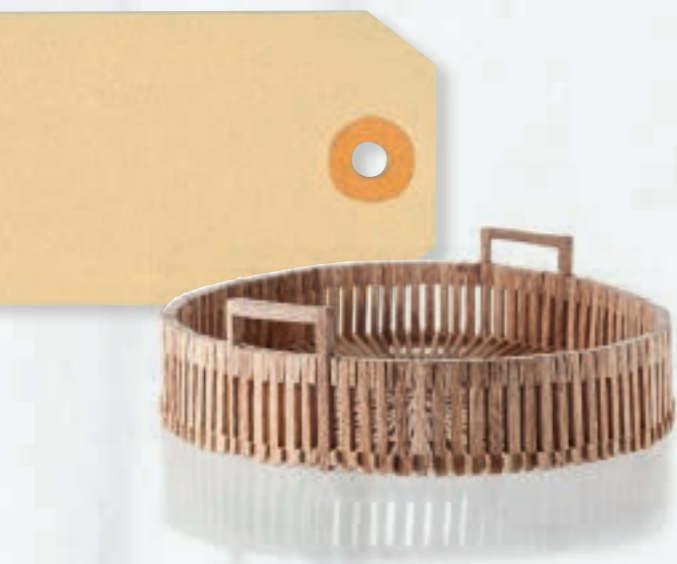

FRASSINO SPAZZOLATO LACCATO BIANCO

Frontali in frassino spazzolato laccato bianco / Vetro texture colore corda / Elemento a giorno laccato grigio medio / Top in laminato porfido 119 bordo unicolor sp. 40 mm / Maniglia prestige cromata / Zoccolo in frassino spazzolato laccato bianco.

WHITE LACQUERED BRUSHED SOLID ASHWOOD

White lacquered brushed solid ashwood and rope textured glass doors / Medium grey lacquered open element / Porphyry 119 laminate top with unicolor edge, th. 40 mm / Handle Prestige chrome finish / White lacquered brushed solid ashwood plinth.



16







Una composizione contenuta ma attrezzata e completa, interpretata in stile moderno senza perdere il senso di eleganza. Gioca sui contrasti tra la raffinata anta in frassino laccato poro aperto bianco e la tecnologia moderna delle finiture cromate della maniglia Prestige e della cappa.

A modest yet fully equipped layout offers modern styling without sacrificing elegance. The sophistication of the white painted open grain ashwood doors contrasts with the high-tech modernity of the chrome finish used for the Prestige handles and the hood.



Tavoli

Tables

1. Asolo laminato

Tavolo Asolo laminato con massello fusto laminato disponibile nei colori frassino anticato, avorio frassinato e frassino bianco. Allungabile su un lato (cm 40).

–
Laminate table with trim and laminate base, antique ashwood wood finish, ivory pickled or white ashwood wood finish. Available with 40 cm extension leaf on one side.

125x70+40, H 72 cm
140x80+40, H 72 cm
160x80+40, H 72 cm
90x90 apribile a libro, H 72 cm

2. Asolo impiallacciato

Tavolo Asolo impiallacciato fusto impiallacciato disponibile nei colori frassino finitura anticata, avorio decapè e bianco poro aperto. Allungabile su 2 lati (cm 40+40).

–
Ashwood veneered top, antique ashwood finished, ivory pickled finished, or white brushed lacquered ashwood. With extension leaves on both sides (cm 40+40).

140x80+2/40, H 72 cm
160x80+2/40, H 72 cm

3. Tavolo Elephant

Tavolo in legno massiccio frassino o rovere, disponibile nelle finiture naturale e laccato poro aperto nei colori Asolo. Non è allungabile.

–
Solid ashwood or oak table available in natural ashwood or Asolo brushed lacquered colors. No extensions available.

160x90, H 77 cm
180x90, H 77 cm
220x90, H 77 cm

4. Tavolo Fratino

Tavolo Fratino impiallacciato frassino finitura anticata o avorio decapè e giropanca impiallacciato frassino finitura anticata o avorio decapè.

–
Traditional table, antique ashwood finish or ivory pickled finished, with veneered bench ashwood or ivory pickled finish, with storage space.

140x80+2/40, H 72 cm
160x80+2/40, H 72 cm

5. Tavolo 666/E

Tavolo impiallacciato essenza frassino disponibile nelle finiture naturale e laccato poro aperto nei colori Asolo, allungabile due lati (cm 50+50).

–
Veneered ashwood table available available in natural ashwood or Asolo brushed lacquered colors, with extension on both sides (cm 50+50).

140x90+2/50, H 76 cm
160x90+2/50, H 76 cm

6. Tavolo 663/E

Tavolo impiallacciato essenza frassino disponibile nelle finiture naturale e laccato poro aperto nei colori Asolo, allungabile un lato (cm 40+40).

–
Veneered ashwood table available in natural ashwood or Asolo brushed lacquered colors, with two available extensions on one side (cm 40+40).

140x90+2/40, H 76 cm
160x90+2/40, H 76 cm

1. Asolo laminato



2. Asolo impiallacciato



3. Tavolo Elephant



4. Tavolo Fratino



5. Tavolo 666/E



6. Tavolo 663/E



Sedie

Chairs

1. Sedia Asolo

Sedia Asolo in frassino naturale finitura anticata, avorio decapè o bianco poro aperto. Con seduta in legno o paglia.

Ashwood chair Asolo antique ashwood finish, ivory pickled finish or white brushed lacquered. With wooden or straw seat.

2. Sgabello Asolo

Sgabello Asolo in frassino finitura anticata, avorio decapè o bianco poro aperto. Seduta in paglia.

Ashwood stool Asolo antique ashwood finish, ivory pickled finish or white brushed lacquered. With straw seat.

3. Sedia Milano

Sedia in faggio tinta naturale o laccata poro aperto nei colori Asolo (no frassino anticato o avorio decapè). Seduta in legno.

Beech chair natural finish or lacquered in Asolo colors (no ashwood antique finish or ivory pickled finish). With wooden seat.

4. Sgabello Lisanne

Sgabello in faggio tinta naturale o laccata poro aperto nei colori Asolo (no frassino anticato o avorio decapè). Seduta in legno.

Beech stool natural finish or lacquered in Asolo colors (no ashwood antique finish or ivory pickled finish). With wooden seat.

5. Sedia Lisanne

Sedia in faggio tinta naturale o laccata poro aperto nei colori Asolo (no frassino anticato o avorio decapè). Seduta in legno.

Beech chair natural finish or lacquered in Asolo colors (no ashwood antique finish or ivory pickled finish). With wooden seat.

6. Sgabello Corallina

Sgabello in faggio tinta naturale o laccata poro aperto nei colori Asolo (no frassino anticato o avorio decapè). Seduta in legno.

Beech stool natural finish or lacquered in Asolo colors (no ashwood antique finish or ivory pickled finish). With wooden seat.

7. Sedia Corallina

Sedia in faggio tinta naturale o laccata poro aperto nei colori Asolo (no frassino anticato o avorio decapè). Seduta in legno.

Beech chair natural finish or lacquered in Asolo colors (no ashwood antique finish or ivory pickled finish). With wooden seat.

1. Sedia Asolo



2. Sgabello Asolo



3. Sedia Milano



4. Sgabello Lisanne



5. Sedia Lisanne



6. Sgabello Corallina



7. Sedia Corallina



Soluzioni Smart

Smart Solutions

ATTREZZATURE INTERNE INTERIOR FITTINGS

Un'ampia modulistica propone soluzioni pensate per valorizzare lo spazio a disposizione, sfruttare al massimo la capacità contenitiva di ogni elemento e per facilitare l'accesso ai vani e alla dispensa.

A wide selection of fittings designed to enhance the space available, maximize the storage capacity of each item and make the contents easy to reach.

BASI AD ANGOLO CORNER BASE CABINETS

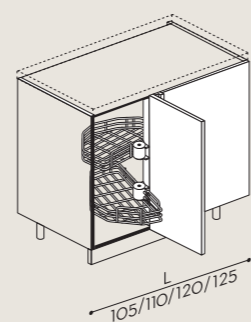
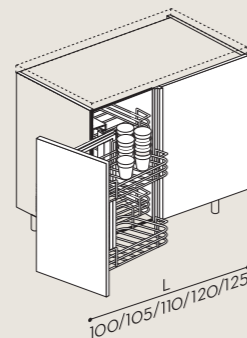
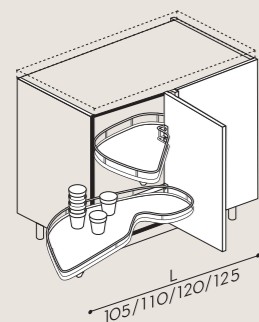

CESTI LEMANS LEMANS FITTINGS

L'angolo attrezzato con cesti LeMans è dotato di cesti estraibili con telaio cromato e fondo antiscivolo grigio, dalla caratteristica forma che ne consente l'estrazione totale. Disponibili per le basi angolo L 105x60; 120x60; 110x65; 125x65 e semicolonne e colonne ad angolo L 105x58; 120x58.

"LeMans" corner units feature pull-out fully extending baskets with chrome frame and grey non-slip coating. Available for the corner base unit W 105x60; 120x60; 110x65; 125x65 and corner tall units W 105x58; 120x58.

CESTI MAGIC CORNER MAGIC CORNER FITTINGS

Sfruttano al massimo la capienza della base angolo grazie ai cesti in filo cromato che traslano aprendo la porta. Disponibili per le basi angolo L 100x60; 105x60; 120x60; 105x65; 110x65; 125x65 e semicolonne e colonne ad angolo L 105x58; 120x58.

These fittings maximize the storage capacity of the corner base cabinets thanks to chrome wire baskets that slide when opening the door. Available for the corner base unit W 100x60; 105x60; 120x60; 105x65; 110x65; 125x65 and corner tall units W 105x58; 120x58.

CESTI MEZZALUNA O CESTI GIREVOLI CRESCENT-SHAPED OR REVOLVING BASKETS

Due pratici cestelli dalla caratteristica forma a Mezzaluna che ruotano facendo perno sul montante della base (per le basi angolo L 105x60; 120x60; 110x65; 125x65). Disponibili anche nella versione cesti girevoli con ante rientranti (per la base angolo L 90x90).

Two practical crescent-shaped swivel basket pivoting on the post of the base cabinet (for the corner base unit W 105x60; 120x60; 110x65; 125x65). Also available with revolving baskets with rotating doors (for the corner base unit W 90x90).

ELEMENTI A GIORNO OPEN CABINETS

Dibiesse si impegna da sempre a proporre soluzioni capaci di valorizzare gli spazi, massimizzare il contenimento della propria cucina, aumentare le superfici di lavoro: proposte progettuali flessibili e mirate a migliorare l'ergonomia della composizione e renderla più funzionale. Ogni modello di cucina può essere caratterizzato e reso più confortevole dalle soluzioni smart.

Dibiesse is committed to offer solutions that enhance spaces, maximize the storage capacity of the kitchen cabinets and increase the surface of work tops: flexible project proposals aimed at improving the ergonomics of the kitchen layout and make it more functional. Every kitchen style can be customised and made more comfortable by smart solutions.

Un tocco di colore e la libertà di esporre gli oggetti più cari: molteplici le occasioni per inserire un elemento a giorno nelle composizioni ed esprimere la propria creatività. Gli elementi a giorno possono essere fatti in essenza o laccato opaco (spessore 12 mm, profondità 353 mm). Disponibili anche con ripiani in acciaio per tutte le altezze L 300 mm e per tutte le larghezze H 240 mm. N.B. Le misure nei disegni sono in cm.

There are many reasons to include open units in your composition: you can add a touch of color, display your favourite objects and express your creativity. Open units are available in wood veneer or matt lacquer finish (12 mm thick panels, depth 353 mm). Also with steel shelves for all heights L 300 mm, and all length H 240 mm. Please note: dimensions on drawings are in cm.

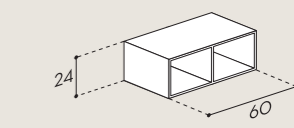
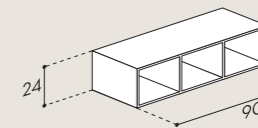
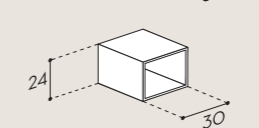
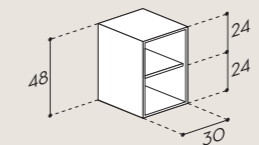
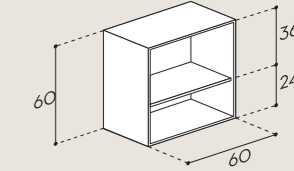
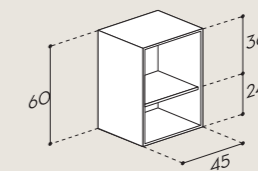
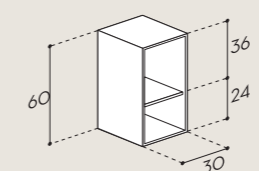
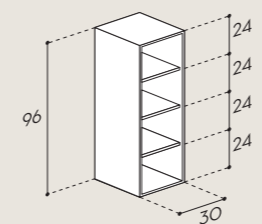
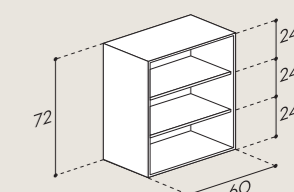
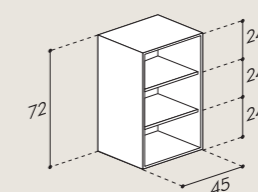
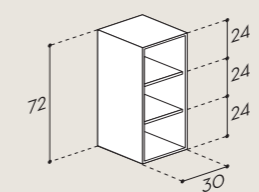
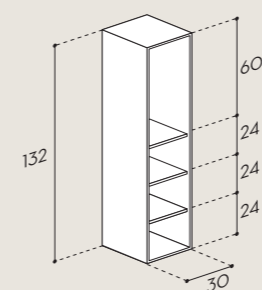

CABINE ARMADIO WALK-IN LARDER UNIT

L'uso di cabine armadio in cucina permette, anche alle composizioni più piccole, di usufruire di un grande spazio di contenimento, attrezzabile a piacimento per diventare dispensa o ripostiglio per lavatrice e piccoli elettrodomestici. Tutte le cabine possono essere dx o sx, di altezza 216 cm o 240 cm. N.B. Le misure sono in cm.

Walk-in larder units in the kitchen allow you to maximize storage space even in small compositions. Depending on your needs, walk-in larders can be suitably fitted to become a pantry or utility room for storing the washing machine and small appliances. Walk-in larders are available R and L with heights of 216-240 cm. Please note: dimensions shown are in cm.

CABINE ARMADIO AD ANGOLO CORNER WALK-IN LARDERS

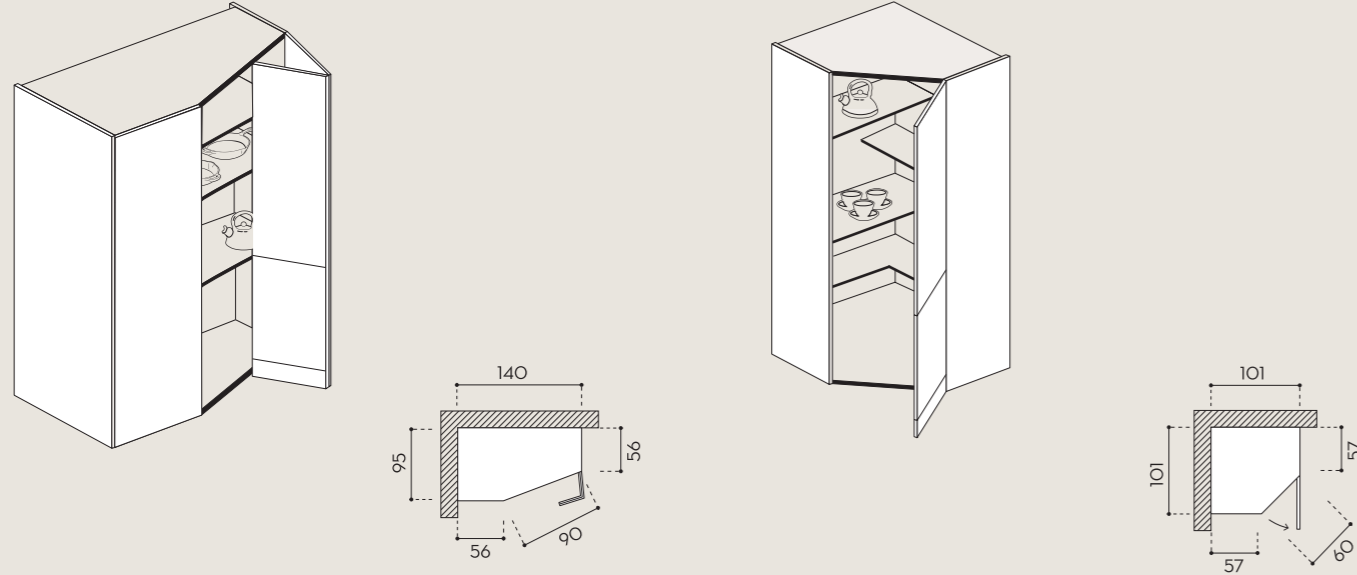

CABINE ARMADIO CENTRALI CENTRAL WALK-IN LARDERS

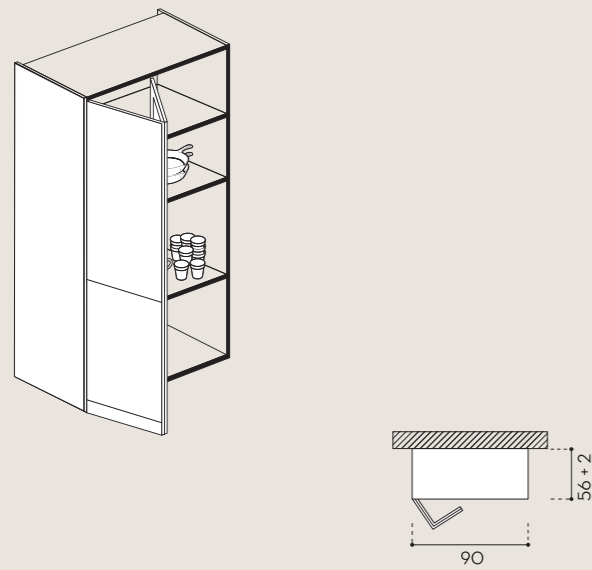

CABINE ARMADIO TERMINALI FINAL WALK-IN LARDERS

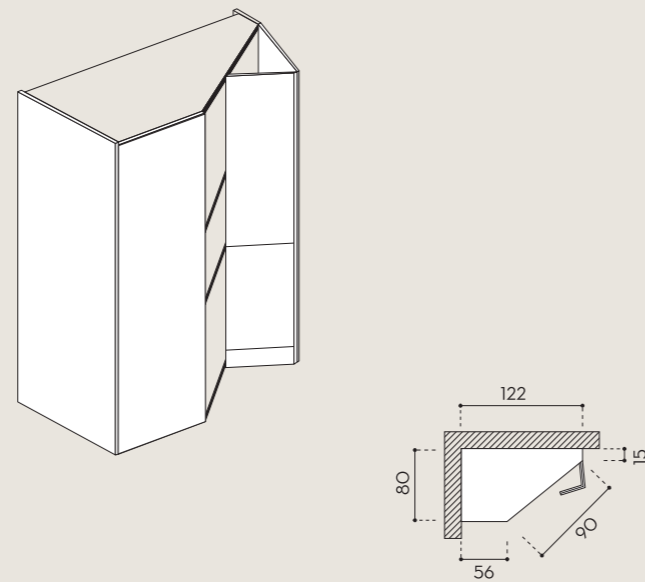

BASI SOSPESSE SUSPENDED BASE CABINETS

Leggere e innovative, le basi sospese sono ergonomiche e possono essere posizionate a diverse altezze in modo da rispondere con efficacia alle diverse esigenze di ogni persona: la cucina diventa così uno spazio aperto e moderno in cui muoversi facilmente. N.B. Le misure sono in cm.

Convenient and innovative, base cabinets suspended off the floor are ergonomically designed and can be positioned at different heights so as to meet the specific needs of each person: the kitchen becomes an open and modern space in which you can move easily. Please note: dimensions shown are in cm.

PROFONDITÀ 35 DEPTH 35

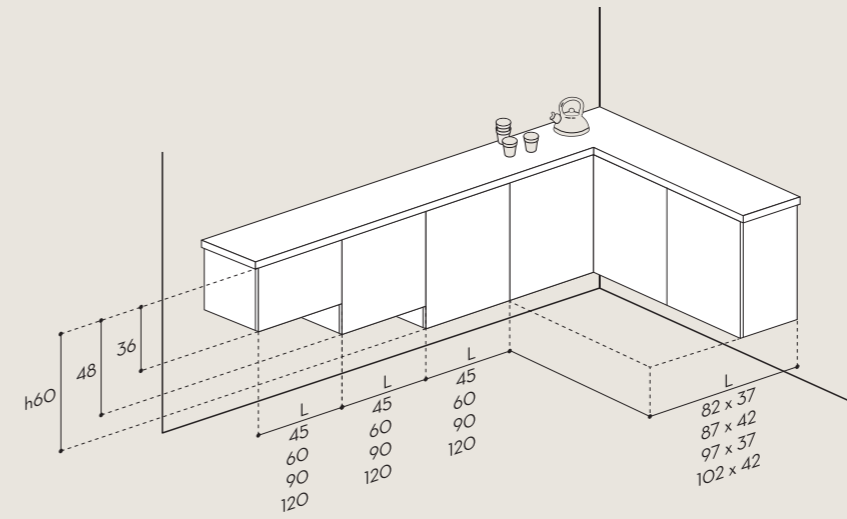

PROFONDITÀ 60 DEPTH 60

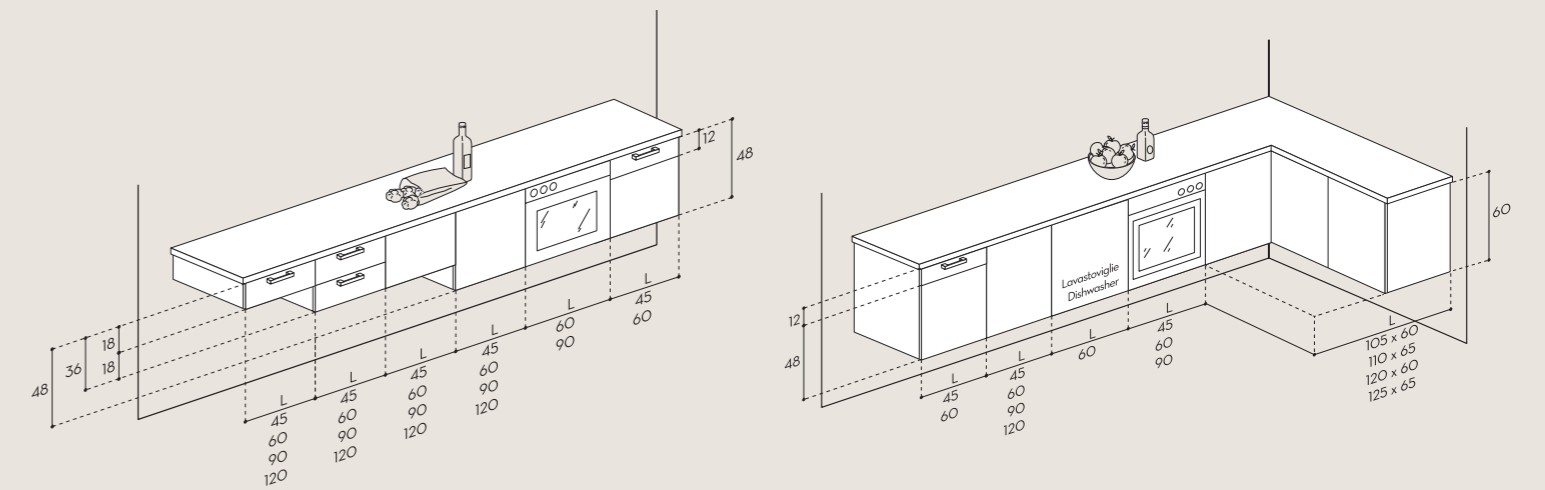

TAVOLI A SCOMPARSA FOLDING TABLES

Soluzioni dinamiche pensate per aumentare le superfici di lavoro, ottimizzano gli spazi e massimizzano la libertà di movimento, per composizioni che si adattano alle esigenze della casa.

Dynamic solutions designed to have extra work space, optimise space and maximise freedom of movement in the kitchen, for compositions that fit your specific needs.

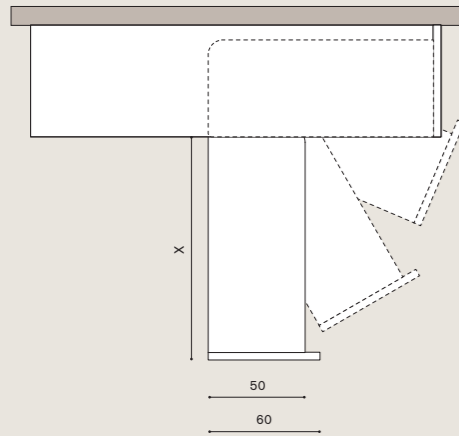

TAVOLO GIREVOLE TERMINALE SWIVEL END TABLE

Il piano si trasforma per offrire maggiore spazio di lavoro e assicurare il massimo comfort nella preparazione dei piatti. Una soluzione pensata per le piccole composizioni. Disponibile in finitura laminato bordo unicolor. Il Tavolo girevole terminale può misurare:

L 110 (spazio utilizzabile 84 cm)
L 140 (spazio utilizzabile 114 cm)
L 170 (spazio utilizzabile 144 cm)
per larghezza 50 cm

The countertop transform itself to offer an additional working space and assure the maximum comfort while preparing the dishes. A practical solution for small compositions. Available in laminate with unicolor edge finish. The End revolving table is available for:

*L 110 cm (usable space 84 cm)
L 140 cm (usable space 114 cm)
L 170 cm (usable space 144 cm)
for the width 50 cm*

TAVOLO ESTRAIBILE PULL-OUT TABLE

Occupi lo spazio di un cassetto e offre quasi un metro di piano di lavoro. Pratico elemento compositivo, ideale per le composizioni più piccole. Il piano ha dimensioni standard L 60-90 x P 80.

It occupies the space of a drawer while offering almost one extra metre of work surface. A very practical element, ideal for smaller compositions. The table has standard dimensions of W 60-90 x D 80.

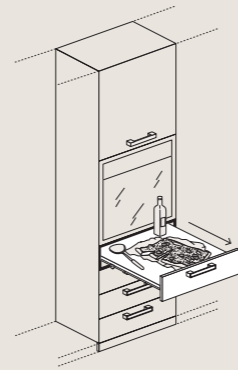

Composizioni del catalogo

Compositions of the catalogue

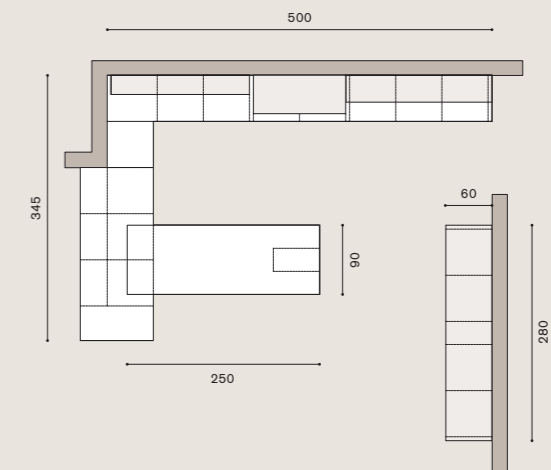
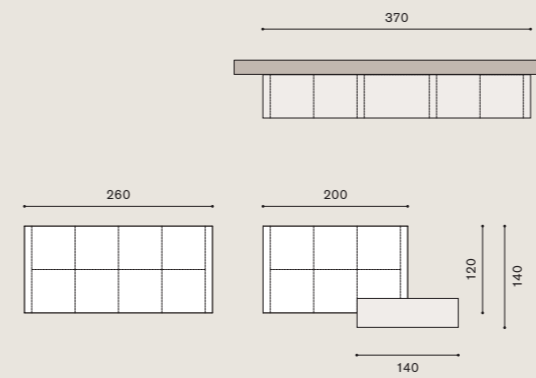

p. 6 1

p. 14 2

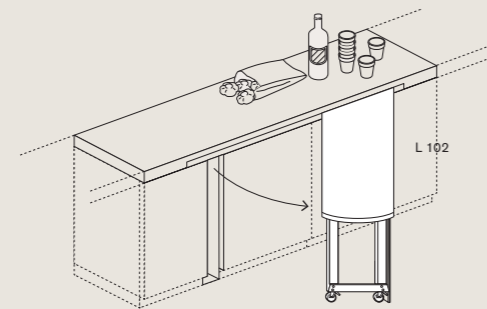
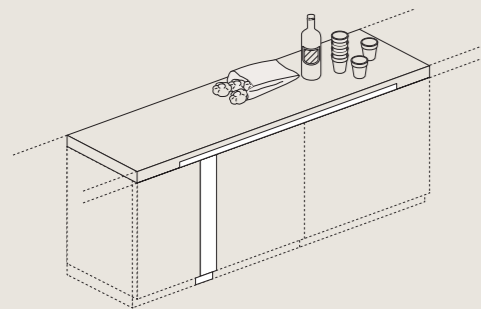

TAVOLO GIREVOLE SOTTOPIANO REVOLVING UNDER COUNTER TABLE

Totale funzionalità operativa del tavolo di servizio estraibile e girevole, con sostegno terminale in metallo verniciato, dotato di ruote per una comoda apertura e chiusura. Il tavolo ha dimensioni standard L 150 x P 50. Aperto misura L 102 x P 50. N.B. Disponibile solo in unicolor.

This table can be pulled out and rotated allowing excellent operational functionality. It features a painted metal frame and wheels for easy opening and closing. The table has standard dimensions of W 150 x D 50. Opened it measures W 102 x D 50. N.B. Available only in unicolor finish.

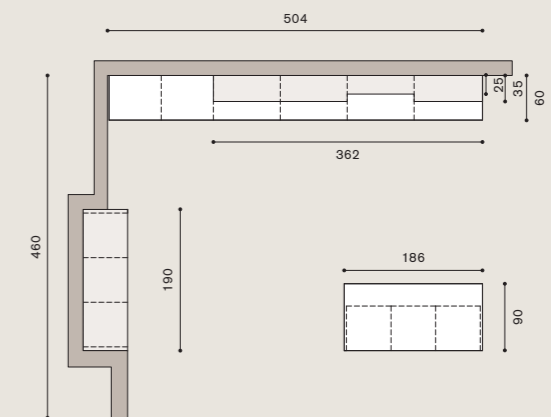
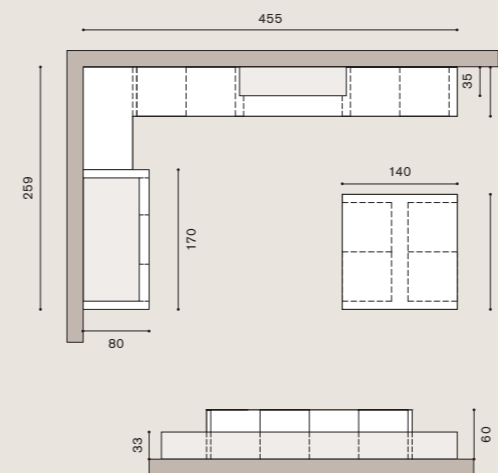

p. 22 3

p. 30 4

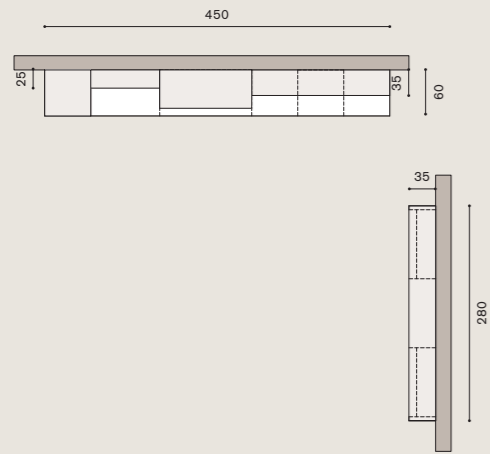

p. 38 5

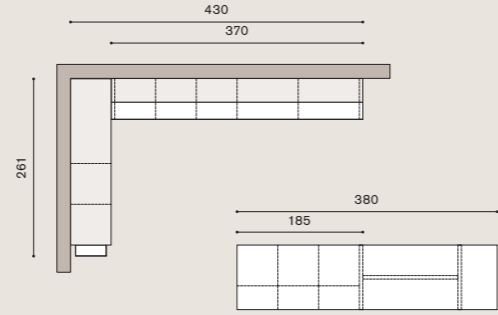

p. 50 6

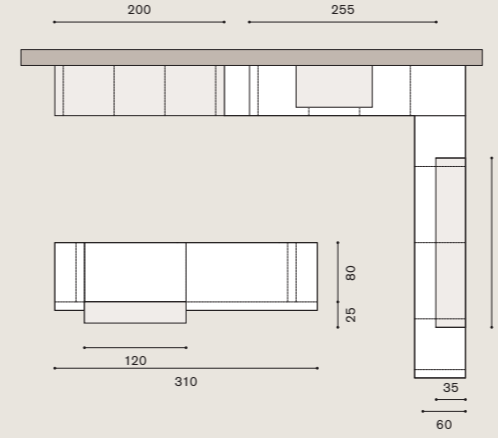

p. 96 11

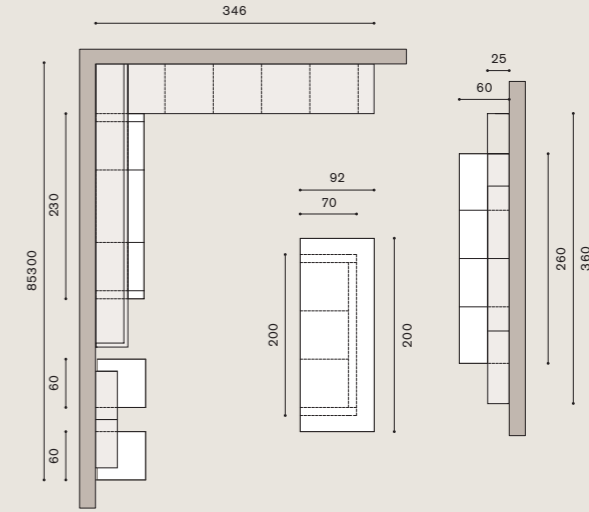

p. 106 12

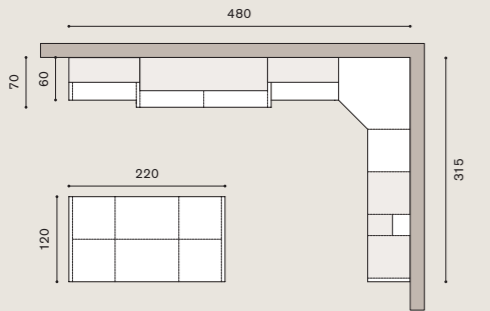

p. 60 7

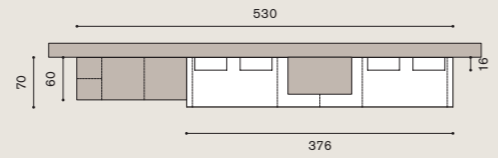

p. 70 8

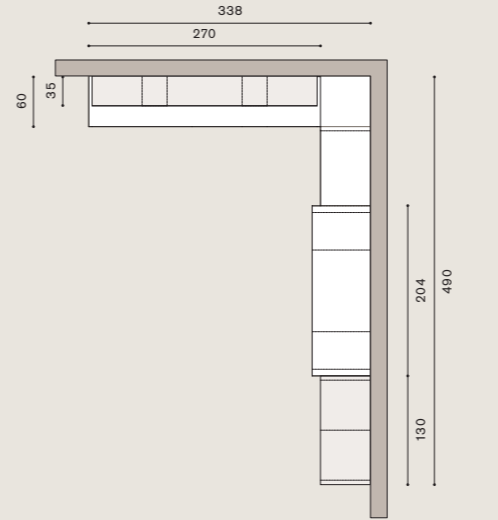

p. 114 13

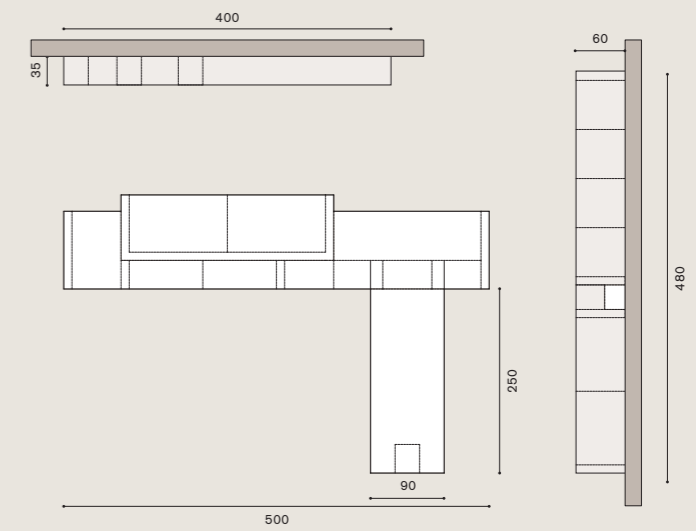

p. 122 14

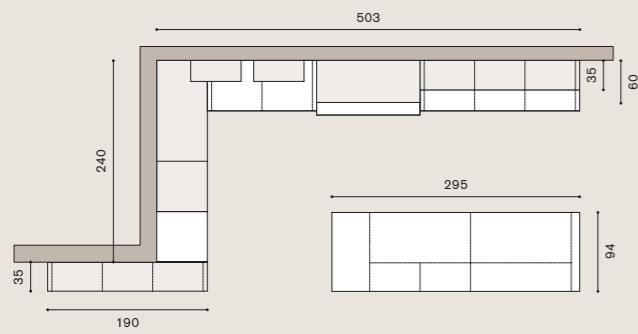

p. 78 9

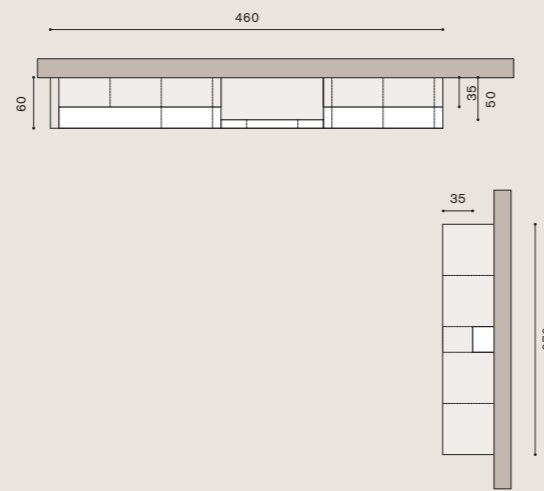

p. 86 10

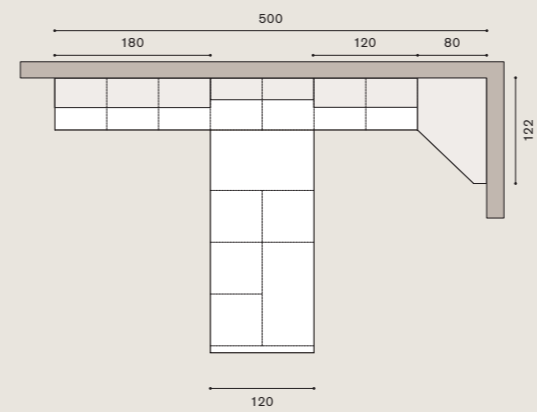

p. 132 15

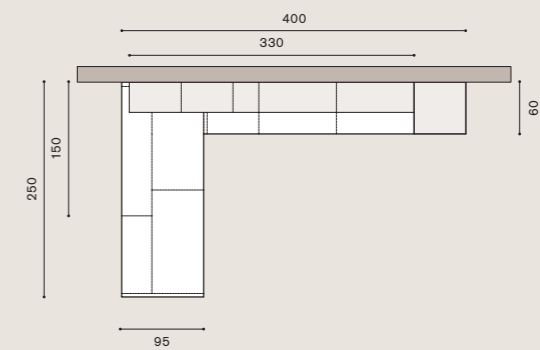

p. 142 16

Ergonomia

Ergonomics

CUCINA A TERRA O SOSPESA KITCHEN WITH TOE KICKS OR SUSPENDED UNITS

L'ergonomia è la scienza che studia il rapporto e l'interazione tra l'uomo, gli oggetti che utilizza e gli spazi dove vive e lavora. L'ergonomia deve considerare requisiti di sicurezza, comfort, usabilità, accessibilità etc. Poichè la cucina è il luogo dove si tende a trascorrere la maggior parte del tempo, è importante che questi requisiti siano rispettati e che le attività possano essere svolte in totale libertà di movimento per non ritrovarsi ad assumere posizioni scorrette e dannose mentre si lavora in cucina. Le misure sono in cm.

Ergonomics is a science that studies how people interact with the objects that they use and the spaces where they live and work. Ergonomics must take into consideration requirements relating to safety, comfort, usability, accessibility, etc. As the kitchen is the place where people tend to spend the majority of their time, it is important that the principles of ergonomics be respected. Activities should be carried out with complete freedom of movement, without having to assume incorrect and potentially harmful postures while working in the kitchen.

Lavorare davanti ad un piano di lavoro troppo alto o troppo basso obbliga ad assumere posizioni scorrette durante la preparazione dei piatti. Dibiesse offre due proposte per creare la propria cucina: a terra o sospesa. La scelta delle basi a terra consente di sfruttare completamente lo spazio di contenimento. Per creare la cucina all'altezza ottimale Dibiesse propone due altezze di zoccoli (H 12 di serie e H 15 su richiesta), diverse altezze di piani di lavoro (a seconda della finitura richiesta) e due altezze di basi, H 60 o H 72 (ma solo H 72 per le basi con i fornelli, perchè impedisce ai bambini di avere accesso al piano di lavoro e ai fuochi). La combinazione di questi elementi rende possibile soddisfare le esigenze di tutti. Lo zoccolo, arretrato rispetto alle basi, è posizionato per facilitare i movimenti e può essere sganciato per permettere la pulizia sotto le basi. La soluzione ergonomica perfetta viene però offerta dalle basi sospese, che consentono di posizionare gli elementi all'altezza ottimale facilitando l'operatività e l'accessibilità alle aree di contenimento. La scelta delle basi sospese facilita la pulizia degli spazi e la libertà di movimento. Inoltre le diverse misure disponibili rendono ancora più libera la realizzazione della composizione. N.B. La tenuta delle basi sospese è subordinata alla tenuta del muro che deve essere portante.

Using a countertop that is too high or too low requires standing in an incorrect position while preparing meals. Dibiesse proposes two different type of kitchen units: ground based or suspended. Ground base units make the most of the storage space. To create the kitchen at a proper height Dibiesse offers toe kicks in two different heights (H 12 standard and H 15 upon request), worktops in a range of heights (according to the finish requested), and two different heights for the base units, H 60 and H 72 (but only H 72 for the hob units as this height ensures that children cannot reach the worktop or burners). The combination of these three elements allow to create a working area adjusted to suit the person. The toe kicks are set back with respect to the base units for ease of movement and can also be removed to clean beneath the units. But the perfect ergonomic solution is offered by the suspended base units, which allow kitchen elements to be placed at the optimum height while also making storage areas more functional and accessible. The choice of suspended base units, which lend a feeling of lightness to the layout as the units appear to be floating. Suspended base units also provide the greatest ease of movement and improve hygiene. They are available in a range of sizes and can be positioned at the desired height, providing greater freedom in kitchen design and making it possible to meet any need. Please note: suspended base units can only be installed on a supporting wall.

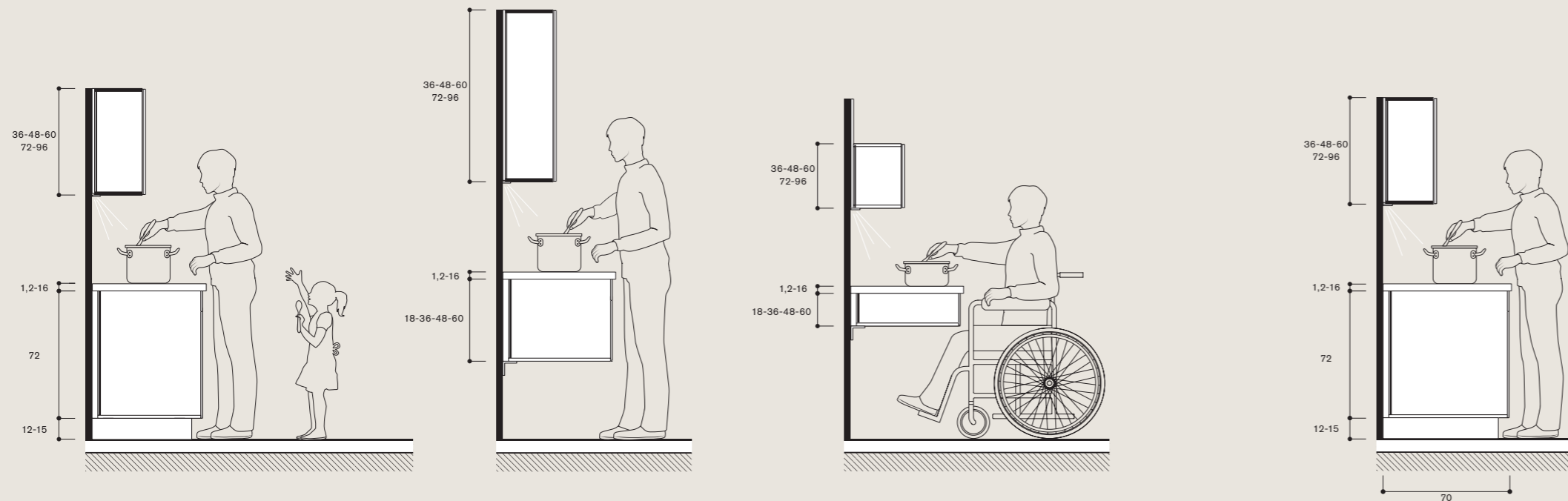

PROFONDITÀ BASI DEPTH OF THE BASE UNITS

Un piano con una maggiore profondità aumenta il senso di libertà permettendo di lavorare con maggiore visuale. Le basi si adattano alla profondità aumentando lo spazio di contenimento. Accessori appositi consentono di organizzarne l'interno. La lontananza dai pensili inoltre facilita l'apertura e chiusura delle ante oltre che il movimento e l'operatività sul piano di lavoro e aumenta la visuale all'interno degli stessi.

A wider worktop offers a sense of freedom and enhances visibility, providing an improved range of vision while working. The depth of the base units is sized to fit the dimensions of the counter, thereby increasing storage space. Accessories can be used to organize the interior space. In addition, the increased distance from the wall units facilitates unit opening and closing, improves ease of movement, enhances the functionality of the worktop and increases the range of vision.

ESTRAZIONE TOTALE DRAWERS OPEN FULLY

I cassetti e i cestoni Dibiesse sono ad estrazione totale: questo consente di avere tutto a vista, facilmente accessibile e, con gli appositi accessori, tutto in ordine. Le guide montate su cassetti e cestoni garantiscono una portata di 40 Kg (per basi profondità 60) e 70 Kg (per basi profondità 70) e sono testate per 60.000 cicli di apertura, dotate di serie del sistema frenante, per la massima portata, durata e comfort.

Dibiesse drawers and large capacity drawers can be fully opened: this enable functionality as the contents are easily visible and accessible. Apposite accessories allow to organize the internal space. Furthermore the guides mounted on the drawers and the deep drawers have soft close runners, to allow to open and close them in total silence. The guides have been tested to withstand 60.000 cycles of movements and guarantee to resist a tonnage of 40 Kg (for the units 60-cm deep) and 70 Kg (for the units 70 cm deep).

LUCI LED LED LIGHTS

L'illuminazione in uno spazio di lavoro è fondamentale. La disposizione dei punti luce all'interno o all'esterno della cucina aumenta la visibilità e il comfort di lavorare in uno spazio bene illuminato e crea atmosfera nella stanza. Dibiesse propone una vasta gamma di accessori per l'illuminazione che utilizzano la tecnologia LED, vantaggiosa sotto molti aspetti: consuma meno, dura di più, non produce raggi ultravioletti e genera pochissimo calore e quindi è più sicura per la salute.

Proper lighting is essential for workspaces. Placing lights both inside and outside of the kitchen to produce a well-lit area enhances visibility and comfort, and adds to the ambiance. Dibiesse offers a wide range of lighting accessories that make use of LED technology. In addition to using less energy and having a longer life, LED lights produce no UV rays, generate very little heat and therefore pose fewer health hazards.

Dibiessi si riserva il diritto di apportare, senza preavviso, modifiche al prodotto al fine di migliorare le caratteristiche tecniche e qualitative del prodotto. I campioni colore e materiali hanno valore indicativo. Testi e disegni presenti in questo stampato hanno scopo divulgativo.

Dibiessi reserves the rights at all time to apply modifications for the functional or qualitative improvement of its products. The color and material samples have an indicative value. Texts and drawings have a divulgative purpose.

Thanks to:
La Ceramica VBC
La Terra e il Fuoco
Le Ceramiche di Miss Dora
Legnoart
Rivadossi Italia
Ruffoni
Pagnossin
02 Store

art direction: **Michele Marcon**
graphics and illustration: **Dogtrot**
photo: **Studio Rocci**
styling: **02 Studio**
photo-retouch: **Lucegroup.it**
print: **Primeoffset**

Febbraio 15/2013





Dibiesse s.p.a.
Via Rossini 28, 31050
Campea di Miane (tv)
T +39 0438.8991
F +39 0438.960035
www.dibiesse.it